

FRAMON

PRECISION TOOLS FOR THE LOCKSMITH PROFESSION



BDK 
Blue Dog Keys





NEW MUST-HAVE TOOLS FROM FRAMON



QUICK PULL REPLACEMENT BLADES

Framon now offers both Kwikset and Schlage blades for the A1 Quick Pull tool. These replacement blades will fit into the Quick Pull and are steel base material that has been hardened. **Kwikset Replacement Blade PART # QPKW**
Schlage Replacement Blade PART # QPSC



SFIC PINNING / CAPPING BLOCK (CPB1)

Another great tool from Framon Manufacturing for locksmiths who use interchangeable core. The CPB1 comes with a pinning / capping block, ejecting pin and capping tool. Insert the core into the tool and eject the old pins quickly and easily. Flip the block over to load the chambers and cap the core. Made in the USA. **PART # CPB1**



KABA PEAKS PINNING / CAPPING BLOCK (CPB140)

A great tool for locksmiths using Kaba Peaks .140 cylinders. The CPB140 comes with a pinning / capping block, ejecting pin and capping tool. Insert the core into the tool and eject the old pins quickly and easily. Flip the block over to load the chambers and cap the core. Made in the USA. **PART # CPB140**



SAFE DEPOSIT KILLER KIT (SDK1)

Framon's new Safe Deposit Killer Kit makes quick & easy work out of drilling S & G and Diebold safe deposit box locks. When traditional methods can't be used due to a plastic or flimsy door the killer kit is your answer. Simply insert the appropriate guide into the keyway and use a hole saw to drill out the face of the plug. Easy entry in minutes. Kit comes with three guides and two-hole saws in an easy to store plastic carrying case. Made in the USA. **PART # SDK1**



TUBULAR LOCK SAW (TLS1)

Framon's TLS1 Tubular Lock Saw allows you to quickly and easily open tubular locks when the key is lost. The TLS1 drills out the bottom pins, giving you the ability to simply insert a blank tubular key and open the lock. The TLS1 fits in any 3/8" or 1/2" drive drill. Call & order yours today! **PART # TLS1**



ABOUT OUR CATALOG

Framon Manufacturing Company began producing key machines for the locksmith profession in 1971. For years our exclusive focus was on key machines for that trade. With the advent of the DC- 300 in 1988, we began to produce key machines for the automotive market as well. Retail locations are also a frequent user of our duplication equipment. In order to help you decide on which machine may be right for your application, each machine will carry the following icons:



Why Buy A Framon / Company History4-7

CODE MACHINES

Framon #2 (Also #1 & #2J)8-10
 DC-300 Duplicating Code Machine 11
 TKM-100 Tubular Code Machine..... 12
 FRA-2001 Computer-Driven Code Machine 13
 KX-1 Code Machine.....14-15
 Sidewinder 2 High Security Code Machine + Duplicator 16

SOFTWARE

Genericode 18

DUPLICATORS

Sidewinder.....17
 DBM-1..... 19
 MD-1 20
 JD-12 21

TOOLS / ACCESSORIES

Frame Dimpling Tool.....22
 Motors22
 Impressioning Tool.....23
 Dial Calipers.....23
 Dual Read Dial Indicator23
 Quick Pull Replacement Blades23
 Safe Deposit Killer Kit.....23
 Tubular Lock Saw23
 Bullseye Installation Jig.....24
 .140 Capping Block.....24
 SFIC Capping Block24
 6 Pin Capping Tool24
 7 Pin Capping Tool24

BLUE DOG KEYS

Popular Keys.....25-29
 Cutting Wheels30
 Replacement Parts31
 Learn More About Framon32



HOW IT ALL STARTED

Framon Manufacturing Company, Inc., was founded by Frank and Barbara Agius, officially in 1971. Below is a short history of the company and some of our major milestones (among other events!). Frank passed away in May of 2003 and Barb in January of 2021. The company was passed on to their children in 1995 after Frank's retirement. In addition to the manufacturing business, the family locksmith shop, which has also evolved into doors, hardware and automatic operators, continues to operate in the same building. Besides one machinist, all Framon employees also work daily in the locksmith shop and test our new products there regularly. Visit the Frank's Key & Lock Shop website – www.frankskeyandlock.com! Enjoy our new catalog and thanks for your interest in Framon products.

Framon Manufacturing Company, Inc



TIMELINE

1955 – Frank & Barb Agius move to Alpena, Michigan from Detroit. Frank opens his own cabinetry business with Barb helping out with bookkeeping duties

1959 – As the need for custom cabinetry begins to wind down, Frank becomes interested in lock work at the suggestion of one of his salesmen. He takes Leonard Singer's correspondence course and begins his career as a locksmith.

1967 – Unhappy with the machinery available to him, Frank designs a key origination machine for his own use. The original machine would become known as the Framon #1 Code Machine. Frank begins work to patent the new invention.

1970-71 – Word of Frank's invention spreads and catches the ear of Sam Solomon, owner of Hugo Solomon & Sons, a locksmith supply company in Detroit. Sam and Frank agree to form a company and market the machine. Putting their names together, "Framon Manufacturing Company" is born. Several of Frank's business associates invest in the company. The first production machine is sold to W E Phillips in New York. Framon is operated out of the family's home in Alpena along with "Frank's Key & Lock Shop".

1975 – With the introduction of Medeco keys that utilize rotating pins, Frank modifies the machine to be able to make angled cuts. The Framon "#2 Dual Code Machine" is produced concurrently with the #1 fixed-spindle version. The #2 will quickly begin to outsell the #1 machine and become the company's flagship machine for over 45 years.

1982 – After a decade of promoting his new code machine, Frank turns his attention to tubular keys. The TKM-100 machine is designed and patented.



1983 – Frank recognizes the need for a new facility and purchases property at 909 W Washington Avenue in Alpena which would be the company headquarters for almost 40 years.

1985 – Frank joins forces with Bill Reed of the Locksmith Ledger and begins touring the country providing free education to locksmiths. The “Frank and Bill Show” makes stops throughout the United States, Canada and Europe over the next 20 years. Other experts in the field will join up with the pair, including Hank Spicer, Steve Young, Gerry Finch, Jerry McNickle, Mark Miller, Michael Miller, Gale Johnson and Joe Bucha. The educational program will eventually be known as “Ledgerworld” and make more than 300 stops, educating almost 10,000 locksmiths at no cost.

1986 – Recognizing the need for an accurate flat steel duplicator, the DBM-1 flat steel key duplicator is invented. Framon now has three code machine offerings and a duplicator.

1987 – A full machine shop is added to the 909 Washington property so almost all production is done in-house. A Fadal CNC machining center is purchased as well as other basic machinery. Frank buys back all of the stock of the company, which is now family owned and operated.

1988 – Assa High Security Locks contracts with Framon to produce a dedicated machine to cut their Twin 6000 keys. The modified Framon #2 machine would be known as the PS-6000T. At this time Framon also introduces a new patented machine, the DC-300. The machine will code cut and duplicate edge cut keys utilizing space keys and depth cams. Several companies in the UK order the machine for their end users.

1990 – With the introduction of high security automotive keys, Frank works jointly with his engineer Darrel Sims to produce a small milling machine to be known as the Sidewinder duplicating machine.

1992 – Framon’s first semi-automatic duplicator for cylinder keys is introduced, known as the Express.

1990’s – Throughout the 90’s Framon introduces several locksmith tools and continue to be a leading locksmith supplier. Trade shows and education continue to be strongholds for the company.

1995 – Frank Agius retires and turns the company over to his two sons and daughter.

1997 – The KX-1 Code Machine replaces the Assa PS-6000T, adding functionality so that a user can change from one manufacturer to another with replacable cams, cutters and vises. Framon jumps into the automatic key cutting market with their first version of the FRA-2001 Computer Driven Code Machine. The machine will originate almost any edge cut key in the market.

2000’s – The turn of the century sees Framon spread into the automotive industry, competing with giants such as Curtis, Ilco, and Silca. Framon grows as a supplier of key machines for the detention industry.

2000 – The MD-1 Manual Key Duplicator is introduced. At this time Framon establishes a relationship that will last more than two decades with Gale Johnson. Gale was given permission to turn the famed Reed Code System into a computer program originally known as Computext, which was sold by the Locksmith Ledger. With the Ledger being sold, Gale and Framon partner up to turn the program into a Windows version. Thousands of locksmiths around the globe utilize the program to retrieve key codes. The program will eventually be known as “Genericode” or simply “Gcode”. Gale would pass away in early 2021 with Framon purchasing his share from his family.

2010 – Framon introduces the JD-12 duplicator for paracentric and mogul-style detention keys.

2014 – Framon partners with Laser Key Products to provide codes for their line of automatic key machines. Gcode is modified to send cutting information to the 3-D Pro, Xtreme and eventually the Elite.

2015 – Framon purchases the assets of the Blue Dog Key Company, after owner Liam Gribben passes away. Framon will move the company to Michigan, expand the product line and set up an online catalog to assist in “odd key” searches.

2018 – After almost 40 years in the same location, Framon moves to a new 6600 square foot building on the main street of Alpena. Frank’s Key & Lock Shop and Framon continue to share the same building and complement each other as sister companies. Product development is largely driven by needs from the lock shop.



OUR PRODUCTS ARE BUILT TO LAST!

All journals are mounted on ball bearings for accuracy and durability. These features are the trademark of Framon Mfg. Co....We feel that only precise equipment will produce precise work.

FRAMON KEY MACHINES ARE A GREAT EXAMPLE OF PRIDE OF WORKMANSHIP!

Our machines are built from steel and aluminum. Each machine is hand-fitted and thoroughly tested before shipment. Sealed ball bearings are used throughout the machine for long life and durability. Other machines use small gears, bushings, and plastic in their build. Framon machines are perfectly happy in the shop or in the van. A bumpy ride in a service van, extremely hot or cold climates won't affect the accuracy of the machine.

CLOSE TOLERANCES MAKE FOR PRECISE CUTS!

The Framon #2 is accurate to .0005" (one-half thousandth, about the thickness of a piece of hair) in both spacing and depth. What are the spacing and depth tolerances of the other machines you are considering? Do they publish tolerances, or just say "It's accurate!"?

NO ROOM FOR MAKING MISTAKES!

The Framon #2 features a straight in feed. This means that the key always approaches the cutter at a 90° angle, and the cut depth on both sides of the cut are the same. Other machines use a pivoting feed, similar to most duplicating machines. The end result? Shallow and deep cuts typically have a "high" and a "low" side. This can lead to keys that turn the lock in one direction but not the other. ***Our cutters are made of hardened steel or carbide and ground to tolerances of plus or minus one-half thousandths of an inch.***

"I operate three mobile vans and have three Framons on them. Two of them are #2's and the other is a #1 (DC). As you can probably guess I wouldn't be without these machines. I have called Phil on several occasions to ask questions or order replacement cutters and he has always been extremely helpful. When I find someone who gives excellent service I very much appreciate it."

-Ed Humes, Locksmith Service Inc.



JUST ASK US!

What kind of customer service can I expect? One of the most important factors in your decision should be support after the sale. At Framon, key machines aren't our only business. We also run a full-service locksmith shop, just like you. When you call with questions on your machine you're not just talking to one of the folks that make the machine, we're also locksmiths. We know all about the things you run into from day to day. The person that answers the phone can usually help you out or quickly or transfer you to someone who can.

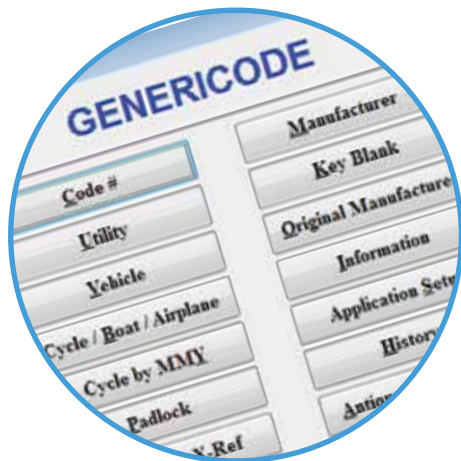
**GREAT SOFTWARE, AN INVALUABLE RESOURCE**

Our Genericode program is known throughout the industry as one of the most comprehensive code programs available. Whether you are a locksmith or automotive dealer, Genericode makes the job of looking up key codes and cutting keys easier than ever. Gcode includes sixteen "programs within a program", allowing you to look up cuts by key code, key blank, and a variety of other ways. Know the cuts (or just a few) but not the code number? Use Gcode's progression program to determine the key code or show a progression list. Gcode will send cutting information to the ITL 950, 9000, Framon FRA-2001, and Laser Key Products Xtreme and Elite machines.

WE STAND BEHIND OUR PRODUCTS!

What type of warranty is included with the machine? If you want to know how confident a manufacturer is in their product, take a look at their warranty. Framon machines carry a one year parts, labor and freight warranty. Any Framon machine found defective in the first year is picked up at your door, repaired or replaced, and dropped off at your door absolutely free! With others, you will most likely pay the freight to get the machine back, and then you can take a number and wait for the repairs to be done. If your machine needs attention after the warranty has expired, it comes in one day and goes out the next. We build an excellent product and back it with a superior warranty. It's easy to do, since repairs are a rarity at Framon!

"Dear Phil, Thank you very much for the new depth and space manual you sent me. I have a very small shop, and most of the time I get the run around from the other companies. I, like you, think people are important. Framon is one of the few companies that put people and the customer first. I have never had a company respond the way Framon did. My little request was just as important as a big order. Once again, thank you so very much. My #2 arrived in perfect condition, and being a machinist myself was adjusted perfect, right on the numbers."

-Scott R. Meister, Scott's Lock & Key Shop



RECOGNIZED THROUGHOUT THE INDUSTRY AS THE MOST ACCURATE & DURABLE CODE MACHINE AVAILABLE

“This is more than a key machine - it is a key origination system”
National Locksmith Article

That alone is probably the best way to describe the Framon #2 Code Machine. When you choose the #2, you enable yourself to originate almost any cylinder key in use today. Here are just a few of the keys you’ll be able to cut with the #2:

- Standard Cylinder
- Domestic Automotive
- Foreign Automotive
- Motorcycle Keys
- Padlock Keys
- Letterbox Keys
- Safety Deposit Box Keys
- Interchangeable Core
- High Security Keys
- Tibbe 6 & 8 Wafer Keys
(with optional vise & cutter assembly)



POSSIBLY THE MOST PERFECT CODE MACHINE EVER CREATED...

All of the extras included with the Framon #2 make it a great package. Here are a few of the features that make it a perfect code machine:

Accuracy: All Framon key machines are hand assembled and hand fit. This ensures that before your machine reaches you, it has originated keys accurate to one-half thousandth of an inch (.0005", about the thickness of a hair). This tolerance assures a perfect key every time!

Straight-In Feed: The #2 utilizes a straight-in feed approach. The straight-in feed of the #2 provides a perpendicular cut at the root of the key. The flat of the cut will always be the same depth from the left side of the cut to the right. Machines that use a pivot approach can produce keys that turn one way but not the other. The drawing at the right shows the profile of a key cut by a machine that pivots. The different shear lines from the left to the right side of the key lead to the turning problem.

Rugged & Durable: The #2 is made from heat treated aluminum and steel. The carriage moves forward on a pair of steel slides. Spacing and depth movements take place on pairs of steel pins and screws. There are no small gears to strip out and no plastic parts to wear out. We’ve heard plenty of stories from code machine owners who have dropped the machine off of their workbench and cut a key with no adjustments needed!



THE REAL BEAUTY OF THE MACHINE IS ITS LOW COST...

In addition to being less expensive than almost any other code machine, keeping your #2 up to date is simple and inexpensive as well. For those of you who enjoy a hard copy of information, use the blank pages in the back of the book to add new depth and space information from sources like trade magazines and locksmith forums online. The included Genericode key code program contains hundreds of additional charts and keeping that updated yearly will give you access to new depth and space information as well.

FRAMON #1/#2/#2J
 Available with **110V AC motor** (standard)
220V AC or 12V DC motors (upcharge)
Dimensions: 10 1/2" W x 17" D x 8" H
Weight: 36 lbs.
 See page 30 for optional cutters

**CUTTING KEYS BY MEASUREMENT ...
UNEQUALED ACCURACY & SIMPLE TO DO**

The #2 utilizes actual space & depth information to cut keys. Here's how it's done...

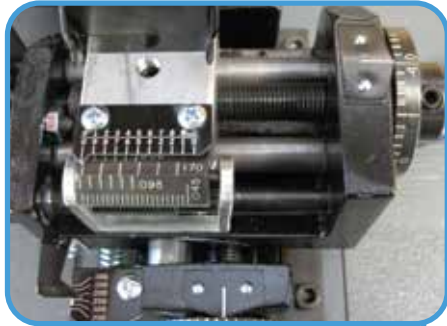

Figure #1

SPACING:

To cut a key, you need two dimensions: starting cut (distance from the shoulder to the first cut) and spacing (distance between cuts thereafter), both found in the Depth & Space Manual or in your Genericode program. Schlage cylinder keys use .231" starting cut and .156" spacing. Starting cut is set by zeroing the machine and counting out to .231". Once set, the spacing block with .156" is aligned. Cut to cut spacing is a simple matter of aligning two index marks. Depth movements take place on pairs of steel pins and screws. There are no small gears to strip out and no plastic parts to wear out.



Figure #2

DEPTH:

Depth settings are made in .001" increments by means of a micrometer. As shown at the left, reading a micrometer is quite simple. Figure #2 shows a micrometer reading .225". The scale shows the pointer is between .200" and .250". The dial reads .025"; add .025" to .200" and you have .225". The micrometer depth reading is what gives the #2 its' extreme accuracy. Once familiar with the machine, you'll be code cutting keys in 30-45 seconds.

The Framon Depth & Space Manual is the core of the Framon #2. The keys mentioned above are only a portion of those that you will have the capability to cut. Key cutting information can also be found in Genericode, which you will also receive with your #2 Code Machine.

The manual contains over 800 cylinder, letterbox and safety deposit charts.

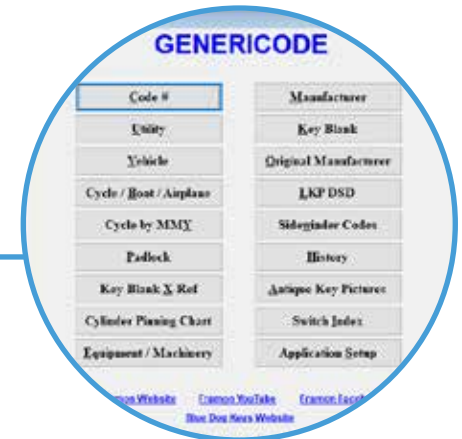



FRAMON #2J DETENTION CODE MACHINE
 THE RENOWNED #2 CODE MACHINE MODIFIED FOR DETENTION USE...

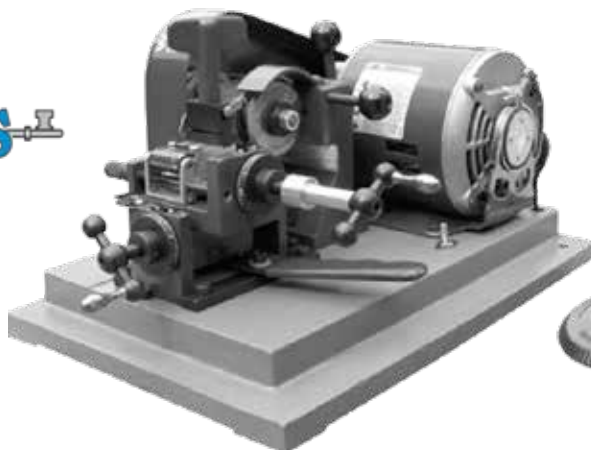

*Accessories
for Framon #2J*



The Framon #2J packs all of the features and benefits of the Framon #2, and adds everything you need to cut Folger Adam, Mogul, Southern Steel, and Adtec keys. A special vise is included with the machine to clamp the larger keys. An extension is added to the spacing crank to avoid interference with the head of these larger keys. In addition to cutting all of the detention keys, the #2J can still be used to cut almost any cylinder key you'll come across. If detention key cutting is your line of work, the #2J is your machine!

EVERYTHING YOU NEED IN ONE PACKAGE...

At Framon, we don't believe in a lot of optional equipment. Here is everything you get when you buy a #1, #2 or #2J Code Machine

STANDARD ON ALL FRAMON #2 & #2J MACHINES

F2MS350	Depth & Space Manual	F2MSSB1	#1 Spacing Block
F2MS451	6" Dial Caliper	F2MSSB2	#2 Spacing Block
FC8445	Standard Cutter	F2MSSB3	#3 Spacing Block
F2MS552	Spacing Clip	F2MSSB4	#4 Spacing Block
DCMS410	Brass Shim	F2MSSB5	#5 Spacing Block
F2MS402	1/8" Allen Wrench	F2MSSB6	#6 Spacing Block

FRAMON #2J ADDITIONAL PARTS

F2SH11J/12J	Jail Vise
F2SH13J/14J	Large & Small Stops
DBC1103.103"	Carbide Slotter
FC9063	Mogul Cutter
F2SH155	Handle Extension

FRAMON #2 (ONLY) ADDITIONAL PARTS

FC8615	Medeco/Emhart Cutter
--------	----------------------



DID YOU KNOW?

Framon also stocks almost every Ilco key blank (non transponder) as well as over 1200 "BD" and "UK" keys - hard to find key for RV's, heavy equipment and hundreds of other applications! Check them out at www.bluedogkeys.com

COMBINES EXTREME ACCURACY AND EASE OF USE

Tired of mis-cut keys due to outdated equipment? The DC-300 combines extreme accuracy (one-half thousandth of an inch) with a simple space key and depth cam system. The DC-300 can both code cut keys as well as duplicate, saving money by utilizing one machine to do both jobs.

EASY TO USE

To code cut keys on the DC-300, insert the proper space key and depth cam into the machine. Turn the depth cam to the proper depth, line up the space key with the proper space position, and push the carriage forward to make the cut. Repeat this procedure for the rest of the cuts on the key. Keys can be code cut in less than 30 seconds.

DUPLICATION IS EVEN EASIER

Turn the depth cam to any number 1 depth on any cam. Insert the original and blank key, and push the carriage forward to make each cut. Duplication takes less than 20 seconds. The DC-300 also features a deburring brush, available in wire or nylon.

SAVES MONEY

Since the DC-300 can both duplicate and code cut, there is no need for two machines. Both tasks are easily done on one machine!

HIGHLY ACCURATE

The DC-300 is precision engineered, and is constructed of steel and aluminum. The machine rarely needs to be adjusted, and holds tolerances of .0005". Sealed ball bearings are used throughout the machine, ensuring years of use. The only maintenance required on the DC-300 is a regular cleaning and few drops of lubricant on the slide rod and depth plunger.

EASILY UPDATEABLE

As new code series are introduced, the DC-300 can be easily updated. In most cases, only a space key is required. Occasionally, a new depth cam will be needed as well. Pair the DC-300 with our Genericode ME software on page 16 for the ultimate in key cutting ease!



DC-300 DEPTH CAM & SPACE KEY KITS

AUTOMOBILE KITS

PART NUMBER	MANUFACTURER	CAMS	KEYS
DCCHR02	Chrysler/Dodge/Jeep/Eagle	100, 200	10, 11, 11A, 11B, 11M, 14, 14A, 71
DCCHR02	Ford	1, 3	12, 13, 13A, 13C, 125A, 131A
DCGMK05	GM/Geo	100, 200	14, 14A, 14D, 14E, 14K, 59, 154, 179, 198, 250, 251, 255, 280, 301
DCHNA02	Acura/Honda	3, 6, 11	14A, 90, 99, 242
DCHYD02	Hyundai	100, 200	108, 108B, 108F, 198, 239
DCISZ01	Isuzu	100, 200, 11	14A, 14E, 90, 179, 198, 242
DCKIA05	Kia	100, 200	108B, 108F, 260, 261, 262, 263
DCMAZ01	Mazda	1, 3	12, 13, 13C, 125, 131A
DCMIT02	Mitsubishi	100, 200	14A, 108, 198, 239, 251, 270
DCNIS01	Nissan	1	13, 13C, 66, 66A
DCSAT04	Saturn	100, 200	11A, 14E, 14K, 280
DCSUB01	Subaru	1	64, 66, 66A
DCSUZ05	Suzuki	100, 200	14A, 14E, 14K, 198, 250, 251, 265, 280
DCTOY02	Toyota	100, 200, 2	14A193, 198, 205, 207, 250, 255

MOTORCYCLE KITS

PART NUMBER	MANUFACTURER	CAMS	KEYS
DCHAR02	Harley Davidson	1,3,5,6,7	603, 609, 611, 612, 613, 620, 625, 633, 634
DCHON04	Honda	6,11	90,603,606
DCKAW04	Kawasaki	1	602, 621, 628, 632, 637, 638
DCSZC03	Suzuki	1	615,619
DCYAM03	Yamaha	1	615, 619, 621
DCFMK06	Foreign Cycle	1,6,11	90, 602, 603, 606, 615, 619, 621, 628, 632, 637
DCBMC01	BMW Cycle	1,200	40, 640, 641

DC-300

Available with 110V AC motor (standard)
 220V AC or 12V DC motors (upcharge)
 Dimensions: 16" W x 10.5" D x 6.25" H
 Weight: 33 lbs.



LEADING THE INDUSTRY IN TUBULAR KEY CUTTING

Framon's TKM-100 is known throughout the industry as the foremost machine in tubular key cutting. Everything you need to originate almost any tubular key in use today is included with the TKM-100:

- TKMS451 Dial Indicator
- TKSH107 Chicago/Dynalock/Unican Cam
- TKSH109 Fort/American Cam
- TKMS102 Ace Spacing Plate
- TKMS103 Offset Right Plate
- TKMS104 Offset Left Plate
- TKMS105 National Keyset Plate
- TKMS106 Ace Change-a-Matic Plate
- TKMS107 Segal 8 Pin Plate
- TKMS108 Universal Spacing Plate
- F2MS402 1/8" Allen Wrench
- TKMS401 3/16" Allen Wrench
- DCMS402 3/32" Allen Wrench

ONE COLLET FOR ALL YOUR NEEDS...

The TKM-100 features a collet that can accommodate all three size tubular keys. No fumbling with changing jaws or adapters. Simply tighten the chuck closer - the self adjusting collet easily accepts any size key (Diameter .365 - .406).

MAKE ANY TYPE OF CUT AND LOTS OF THEM!

With the TKM-100 you can make regular cuts, ward cuts, and master cuts. The machine is equipped with a carbide cutter, which means you can cut brass or steel and get long cutter life.

WHY CODE CUT WHEN YOU CAN DUPLICATE?

Probably more than any other type of key, a tubular key wears very quickly. Due to the constant pressure on the face of the key, even original keys can be off .001" - .003". By using a duplicator to make a key, an inaccurate copy of a worn key is being made. When you use the TKM-100 to code cut a key, you'll be making an original key, accurate to .001". A precision dial indicator is included with the machine, which enables you to decode a tubular keys for duplication. Decoding takes only a few seconds.

SOME OF THE KEYS THAT CAN BE CUT ON THE TKM-100™

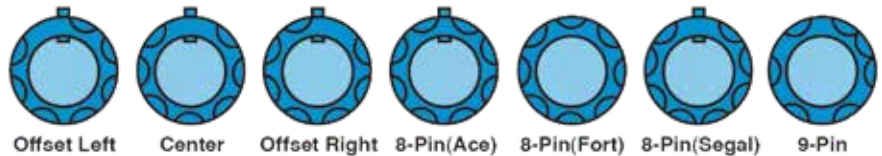

"I have to say that Framon really does have the best customer service out there. You add that to a machine that lasts a lifetime and does all you need in the code department and you just can't go wrong buying a Framon. It's pleasure to deal with someone who treats you like they appreciate your business."

-George Henderson, Another satisfied customer

TKM-100

Available with **110V AC motor** (standard)
220V AC or 12V DC motors (upcharge)
Dimensions: 8" W x 14" D x 10" H
Weight: 33 lbs.

FULLY AUTOMATIC CODE CUTTING

The FRA-2001 is packed with features you'll use daily. More than just a computerized code machine, here is just a sampling of the machine's capabilities.

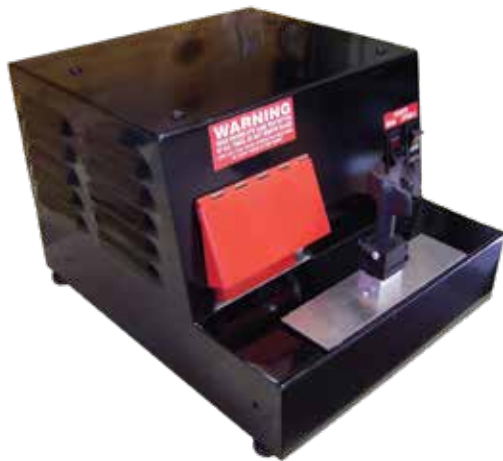
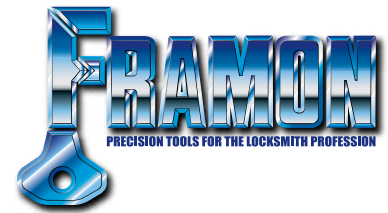

THE MACHINE

The FRA-2001 machine is completely controlled through a serial cable by our Genericode ME software (see page 16 for more information). The machine has no keypad or identification numbers to be confused by when trying to cut a key. Once information is sent, the machine can cut a six-pin key in about 15 seconds. The two servo motors are covered by a two-year warranty, and the control box is covered by a lifetime warranty. Ball screws and sealed ball bearings are used for smooth motion on both axes. A reversible vise is included with the machine, complete with shoulder and tip stops. The FRA-2001 does not have the capability to make angled cuts for Medeco keys.

THE SOFTWARE - LOOKUP & CUT A KEY BY MANUFACTURER

In the Manufacturer's section, the Genericode software allows you to cut a key when the bitting is known. You can search alphabetically by manufacturer's name, series or key blank number. Enter your own information for new series, or make a customized chart. All database information is completely editable. Once you have chosen the chart you wish to cut a key for, simply enter the cut numbers and click the "Cut Key" button. If you simply want to generate a random key bitting for rekeying purposes, click the random icon and a bitting will be generated. The software enables you to plunge cut or laser (profile) cut the key. An image of the key to be generated can be viewed with the click of a mouse.

LOOKUP & CUT A KEY BY CODE

The Codes section allows you to look up almost any domestic or imported code you'll run into. You can also search the database by key blank or partial cuts. The program will also show a progression chart for any partial code you enter. Once the code or progression is determined, use the machine to originate your key.



MACHINE HISTORY: LOOKUP KEYS CUT ON THE MACHINE PREVIOUSLY

The software includes a History database, where you can enter your customers' name and other pertinent data to link with a key you have cut on the machine. Easy retrieval in the future is a snap - simply click the mouse and your key is ready to be originated!



APPLICATION SETUP SECTION

All movements of the FRA-2001 Code Machine are completely controllable by the user. If the machine ever needs adjustment, depth and spacing are adjusted from the Machine Section. Feed rate and other machine functions are also adjusted from this section.

FRA-2001
 Available with 110V AC Motor
 or 220V Motor Available at Extra Charge
 Dimensions: 14" W x 15" D x 11" H
 Weight: 65 lbs.

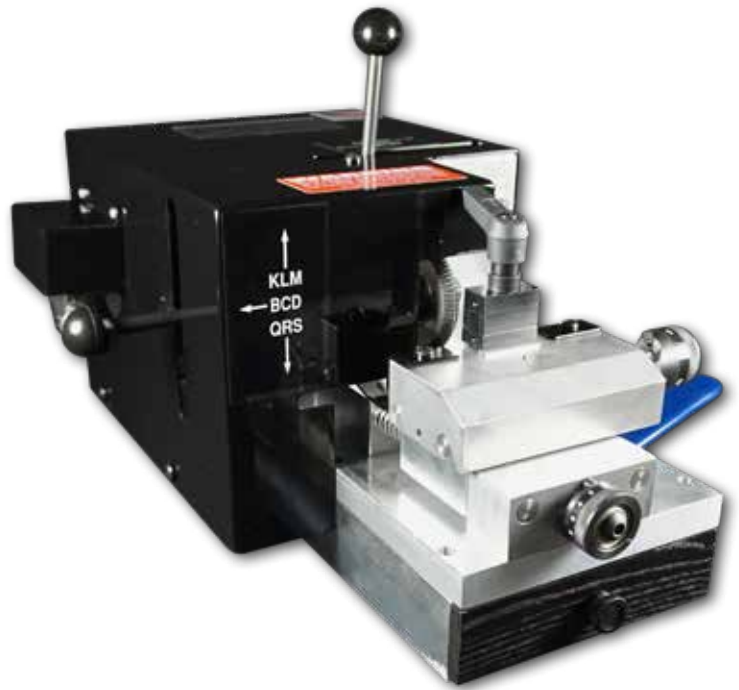

REVOLUTIONIZING HIGH SPEED CODE CUTTING

The KX-1 is designed to quickly and accurately code cut cylinder keys, and in particular, high security keys. The KX-1 uses interchangeable depth and space cams to cut just about any cylinder key in use today. The cams take only seconds to interchange, and no adjustment is needed from one manufacturer to the next.

The machine has been tested thoroughly on locks such as Medeco, Assa, Schlage Primus, Kaba PEAKS, and Best. Assa offers the KX-1 to their end users for cutting Twin 6000 and V-10 keys.

The machine is capable of cutting keys accurate to .0005" in about fifteen seconds. For interchangeable core type keys, the vise has a built-in tip stop. For others such as Medeco or Schlage, a shoulder stop properly aligns the key.

When switching from one manufacturer to another, simply remove an allen screw to take the cam off of the machine. Reinstall the screw to put the new cam on the machine. Of course, depending on which type of key you plan on cutting, a cutting wheel change may also be necessary. Patented keys such as Medeco KeyMark may also need a vise change to properly hold the key.

When purchased, the KX-1 comes set up for whichever manufacturer you prefer. Additional cams, cutters and vises can then be purchased separately based on your needs. Kits are available for a variety of manufacturers - See page 15.

The KX-1 is ideal for institutional locksmiths using only one or two key systems. Locksmiths who do large masterkey systems or routinely cut high security keys will also appreciate the new KX-1.

A prefix is needed to specify which cams will be on the machine. Please see the kits on the next page to determine the correct prefix. Example: For a KX-1 with Schlage cams and cutter, the order number would be KX1-SC.



"Since 1988, ASSA has been furnishing our end users with the KX-1 code machine. We know we can count on the machine to make key cutting an easy job. It is the most accurate and precise key machine we have found for cutting our high security ASSA key blanks. Add to that the fact the machine rarely needs adjustment - a great key machine in every way!"
-Tom Demont, AHC/C ML Former National Sales Manager

KX-1™
 Available with **110V AC motor** (standard)
220V AC or 12V DC motors (upcharge)
Dimensions: 13" W x 14" D x 13" H
Weight: 33 lbs.



CAM AND CUTTER KITS FOR THE KX-1

MANUFACTURER	SPACE CAM	DEPTH CAM	CUTTER	WISE	PREFIX
Arrow	1	S	FC9045	1	AR
Assa	2	A	FC9032	4	AS
Assa MK "0"	2A0	AM	FC10416	4	AM
Best A-2	13	P	FC9054	2	B2
Best A-3	13	N	FC9054	2	B3
Best A-4	13	M	FC9054	2	B4
Corbin D,H,Z Sys 70	3	B	FC9054	1	CD
Corbin Pyramid	PY1	PY	FC9054	1	PY
Corbin K,N Sys 70	3	D	FC9054	1	CK
Corbin X Pre 70	12	E	FC9054	1	CX
Corbin X Pre 70	12	CX	FC9054	1	CXP70
Corbin GH	4	X	FC9090	1	KW
Corbin 981	3	Y	FC9054	1	C9
Corbin Z Pre 70	3	Z	FC9054	1	ZC
Dorma D Series	DR	P	FC9054	1	DD
Emhart	3	F	FC8612	1	EM
Falcon Standard	7	R	FC9090	1	FS
Falcon I-Core	13	P	FC9054	2	FI
Grundman	16	G	FC9051	1	GR
Kaba Peaks 140	15	P	FC9054	2	K4
Kaba Peaks 150	13	P	FC9054	2	K5
Kwikset	4	X	FC9090	1	KW
Kwikset Titan	14	X	FC9090*	1	KT
Lockwood	20	U	FC9045	1	LK
Master	9	L	FC9045	1	MS
Master Padlock	17	Z	FC9045	1	MP
Medeco Bi-Axial	6	T	FC8615	1	MB
Medeco Commercial	5	V	FC8615	1	MC
Medeco KeyMark	13	W	FC9054	3	MK
Medeco M3	6	T	FC8615	M3	M3
R R Brink Mogul	J2	JC	FC10070	BRM	BRM
R R Brink Lever	J5	JE	DBC1045x2	DET	BRL
Ruko (UK)	19	A	FC9032	4	RK
Sargent C,R,L	10	J	FC7863	1	SR
Sargent U,R,K,G,T,UT	10	H	FC7863	1	SU
Sargent Degree DG1	5	DG1	FC9054	1	DG1
Sargent Degree DG2/DG3	5	DG2	FC8615	M3	DG2
Schlage (includes Primus)	8	C	FC10031	2	SC
Schlage SFIC	18	P	FC9054	2	ST
Southern Folger Mogul	J2	JC	FC10070	DET	SFM
Southern Folger Maxi Mogul	J2	JB	FC10070	DET	SFMM
Southern Folger 6 Lever	J1	JA	DBC1088	DET	SF6
Southern Folger 5 Lever	J3	JD	DBC1103	DET	SF5
Southern Folger 5 Lever**	J4	JD	DBC1103	DET	SF50
Southern Steel Mogul	SJ2	JF	FC10070	DET	SSMN
Southern Steel A Series	J6	JD	DBC1103	DET	SSA
Southern Steel 13 A1***	None	JF	DBC1085S	DET	SS13
Weiser	7	R	FC9090	1	WE
Yale Pro-Key	22	O	FC9045	1	YP
Yale Standard	11	K	FC9045	1	YA

*Kwikset Titan models are shipped with the FC9090 cutter. A separate charge (included upon request only) will be added for the FC4590T cutter for making the first cut next to the shoulder of the key, which has a 90 degree angle at the bow side.

**This configuration only for older 0-100, 200-300, 400-500 series.

***The Southern Steel A1 machine is NOT capable of any interchange with other cams or key series.



ORIGINATE AND DUPLICATE HIGH SECURITY AUTOMOTIVE KEYS...

Framon's Sidewinder 2 takes the original Sidewinder one step further, allowing you to originate high security keys as well as duplicate.

DUPLICATES ALMOST ANY HIGH SECURITY AUTOMOTIVE KEY IN USE TODAY...

The Sidewinder 2 includes everything needed to duplicate just about any high security key in use today. Two sets of vises, seven cutters and three guides are included at time of purchase. With the Sidewinder 2 you'll be able to duplicate Mercedes, BMW, Lexus, Infiniti, Kia, Hyundai, Chevrolet, Pontiac, Volvo and Saab just to name a few.



CODE CUTTING MADE EASY

Depth and space "rods" are furnished with the machine. The rods operate similar to cams to position the carriage properly for each cut needed. Changing the machine from a duplicator to a code machine takes about one minute. Depth & space rods are available for almost all high security keys in use today. The rods screw into the machine & reach a positive stop for proper alignment each time without the need for adjustment. Once the rods are in place, the user simply tightens the lock screws and the machine is ready to code cut. Choose three kits when you purchase the Sidewinder 2.

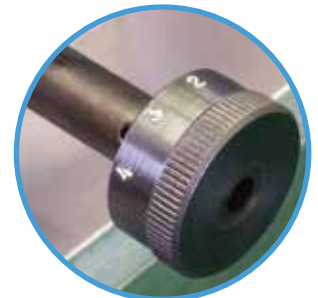

SIDEWINDER 2 ROD KITS

MANUFACTURER	PART NUMBER	CODE SERIES
BMW 2 Track	GHMS764	HBA0001-6000
Chevrolet	GHMS751	Z0001-6000
Chevrolet	GHMS751	V0001-5573 GM
Fiat / Chrysler	GHMS761	DE00001-11210
Ford	GHMS762	10001-11500
Ford	GHMS762	11501-13000
Honda	GHMS754	K,L,M,N000-999
Hyundai	GHMS757	G0001-2500
Hyundai 2 Track	GHMS766	T1001-3500, C1001-3500
Kia	GHMS752	L0001-1000
Kia	GHMS757	G, K0001-2500
Infiniti	GHMS753	0001-2000
Lexus Long	GHMS752	O0001-5000
Lexus Short	GHMS752	40000-49999
Lexus Emergency Key	GHMS765	80000-89999
Mazda Mellenia	GHMS752	20001-21200
Mercedes 4 Trk	GHMS756	700001-703000, HS,NS2001-3500
Saab	GHMS759	BC0001-2865, 2S0001-2S2675
Subaru	GHMS760	T0001-3000
VW / Audi	GHMS755	HAA0001-6000

SETUP KEYS

Each pair of code rods is accompanied by a "setup key". This key helps the user to properly set the depth of cut. The setup key is also used to prepare a blank for code cutting. The user actually duplicates all shallow cuts on to their blank as well as the tip cuts. Once the blank is prepped, code cutting can take place.

SIDEWINDER 2
 Available with **110V AC motor** (standard)
220V AC or 12V DC motors (upcharge)
Dimensions: 6" W x 14" D x 10" H
Weight: 33 lbs.
 See page 30 for optional cutters & accessories

SMALL AND COMPACT, THE SIDEWINDER CAN HANDLE ALL OF YOUR NEEDS

The compact Framon Sidewinder has been the professionals' choice since it was introduced to the market in 1990. It is designed to quickly and accurately duplicate automotive high security keys such as Mercedes 2 & 4 Track, BMW, Lexus, Infiniti, Volvo and Saab.

A COMPLETE KEY CUTTING "STATION"

When you choose the Framon Sidewinder, you don't just get a duplicating machine. Four cutters come standard with the Sidewinder. Two 5/32" and two 3/32" cutters come with each machine. The 5/32" is used for cutting most externally cut high security keys. The 3/32" is used for center cut keys such as Lexus. These cutters are made of carbide and cobalt for long life and durability.

You'll also receive Free Volkswagen/Audi Vises for the machine. No need to purchase any additional components to do the job.

EASY OPERATION

The Sidewinder now features a lever on the left side of the machine to control all carriage movements. We've updated the table for extremely smooth movement. In addition, our vises do not require adapters or additional clamps to hold any keys. Two sets of reversible vises hold every high security automotive key you'll come across. The Sidewinder also has a storage drawer under the machine to hold cutters, vises, and tools. Setting up the machine takes less than a minute, and duplicating a key can be done in about 30 seconds per side. The feature don't stop there...

DURABLE CONSTRUCTION

As locksmiths around the world have come to expect, ball bearings are used extensively throughout the machine. Aluminum and steel construction means you are buying a machine that will hold its' tolerances and hold up to rough use. Make the best choice - the Framon Sidewinder.

Sidewinder duplicators can be upgraded to the Sidewinder 2 Code machine at a later time.



"I own one of your Sidewinder key machines. I tried all of the others at a show and found that yours was the best suited for originating keys. I've had it for about 2 years now and have never had a problem with it."

- Ken Cox, Eugene, OR

Note: Our Sidewinder machine is designed as a duplicating machine, but with space and depth keys, you can originate side-milled keys with it.

SIDEWINDER™

Available with 110V AC motor (standard)

220V AC or 12V DC motors (upcharge)

Dimensions: 6" W x 14" D x 10" H

Weight: 33 lbs.

See page 30 for optional cutters & accessories



MORE THAN JUST A CODE LOOKUP PROGRAM

GCODE Desktop: The Total Code Retrieval System



FEATURES OF GCODE

- General Code Program: Lookup key information from a code number
- Utility/Vehicle/Motorcycle/Padlock Programs: Lookup key information by manufacturer, model, and input codes or cuts.
- Key Blank Search: Don't know the manufacturer? Find out if you know the blank number.
- Depth & Space Program: Lookup depth & space information for virtually any lock in use today.
- Progression Program: Displays a chart to progress keys when only partial cuts are known.
- Sidewinder Codes: View a full list of all known Sidewinder key codes in the program.

Key blank information is shown for the following manufacturers: Ilco Standard, X, E-Z, Dominion, Curtis, Jet, Star, ESP, Borkey, Silca, Orion, and Original.

In addition, Genericode™ displays the keyway and cut key profile. Key cutting information is included for Framon, HPC, ITL, Ilco, A1, Silca, and Laser Key Products key machines. Genericode will download cuts to the Framon FRA-2001, ITL 950/9000, and Laser Key Products Xtreme and Elite.

Some code programs boast of their numbers of codes included, claiming over two million; Genericode™ contains over 750,000 codes for combination padlocks alone! Add to that over 200,000 codes for ten cut GM and over 100,000 for ten cut Ford; doesn't two million seem a little light? Genericode™ contains well over 4,500 code series, ask others how many they have....

...Add to that a key blank cross reference program and a motorcycle model database and you get the complete code lookup program.

Other companies are happy to sell you a code retrieval program, another program for progression charts, and another for missing cuts. Genericode™ gives you all of these programs at once, and you can run any of them out of the same window.

Unlike other programs, Genericode is licensed to your location; you may install it on all computers in your shop or your trucks. Additional authorizations are not needed. Also, yearly updates are optional; you are not forced to pay for an update every year.

Genericode runs on Windows Operating Systems.

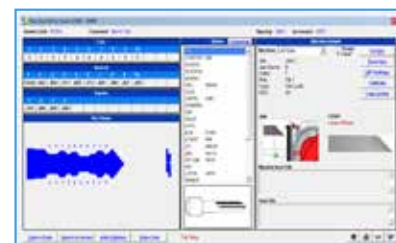

GCODEONLINE

Prefer not to carry a laptop? Sign up for a yearly subscription to Gcodeonline at www.gcodeonline.com. The online version will not send cutting information to electronic machines but will print HPC cards, handle key progressions and has all of the features that our desktop version has!



MAKES FAST WORK OUT OF FLAT STEEL KEY DUPLICATION



ALL THE QUALITY YOU'VE COME TO EXPECT FROM FRAMON...

The Framon DBM-1 is designed to cut safety deposit box, locker, and padlock keys. This specialized flat key duplicator will duplicate blanks up to 3 1/2" long. The DBM-1 features a wire deburring brush (nylon also available) and carbide cutter.

ROTATING GUIDE FOR DIFFERENT CUTTER WIDTHS.

The DBM-1 features a rotating guide which can be paired up to six different cutter widths. Widths available in .035", .045", .055", .066", and .088". A .100" cut can be made by pairing the .045" and .055" cutters.

THE FRAMON DBM-1: DESIGNED TO DO ONE JOB AND DO IT RIGHT...

Depth adjustments can be made in .001" increments. As with all Framon products, sealed ball bearings are used in the spindle. Built-in rod wipers keep the carriage rod clean as you cut keys.

You can expect years of trouble-free service from your DBM-1. Cut Master Padlock corrugated keys, locker, letterbox, and safety-deposit box. Even cut two keys at a time!

SAFETY DEPOSIT BOX KEYS

Diebold, Master, Yale Sargent & Greenleaf Victor, LeFebure, HHM, York.



LOCKER & LETTERBOX KEYS

Yale, National Eagle, Auth, Couch, Florence,



PADLOCK KEYS

Single and double sided
Master.

Rotating stylus changes easily to 6 different guide widths of .035, .045, .055, .066, .088, .100.

Precise adjustments - no guesswork.

Guide easily locks in rearward position for easy tip alignment, no spring pressure.

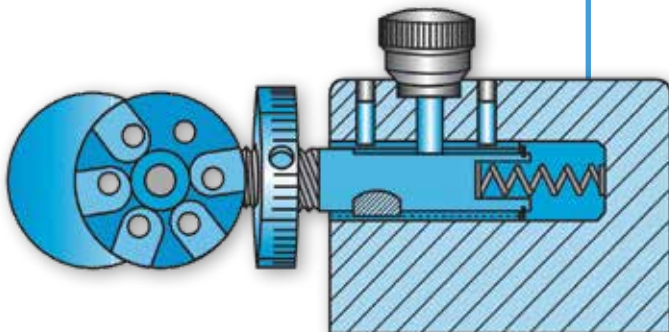

DBM-1™

Available with 110V AC motor (standard)

220V AC or 12V DC motors (upcharge)

Dimensions: 10.5" W x 16" D x 6.25" H

Weight: 33 lbs.

See page 30 for optional cutters & accessories

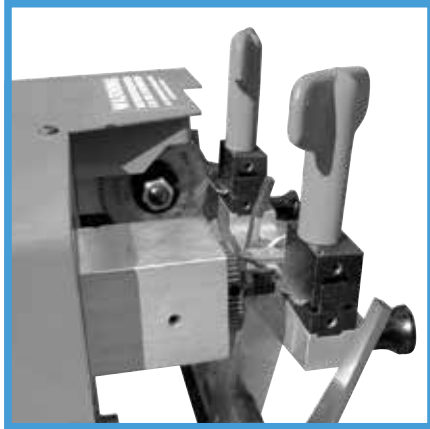

THE QUICK AND EASY WAY TO DUPLICATE KEYS

The MD-1 is a manual duplicator designed for locksmiths, automotive dealerships, and hardware stores to cut a wide variety of keys without the need of additional accessories.



HERE ARE JUST A FEW OF THE FEATURES OF THE MD-1:

- Can accept keys up to 4" in length
- 1-7/8" of cutting travel
- Wire deburring brush included (nylon also available)
- 1/6 hp motor included
(12 volt available - upcharge for 12 volt motor)
- Reversible vises hold a wide variety of keys without tipping
- Flip-down key stop for aligning shoulders or tips of keys
- Adjustable guide (.001" increments)
- Carriage wipers to keep chips off of yoke rod
- Sealed ball bearings in spindle assembly

Framon's MD-1 offers you the ability to cut almost any cylinder key in use today. Keys can be cut quickly, easily, and accurately. If adjustments are ever needed, they can be made in .001" increments. The MD-1 carries Framon's one-year, parts, labor and freight warranty.

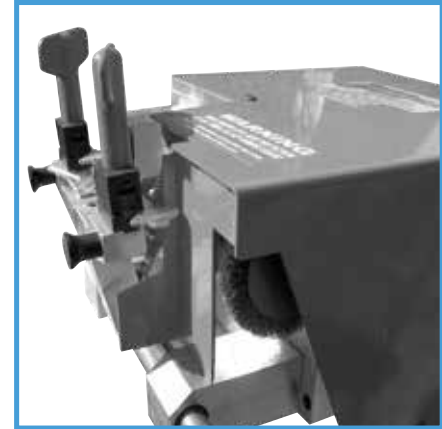

MD-1™
 Available with **110V AC motor** (standard)
220V AC or 12V DC motors (upcharge)
Dimensions: 12" W x 15" D x 6" H
Weight: 29 lbs.

**TAKING PRECISION DUPLICATING TO THE NEXT LEVEL
WITH SMOOTHER USER CONTROL**

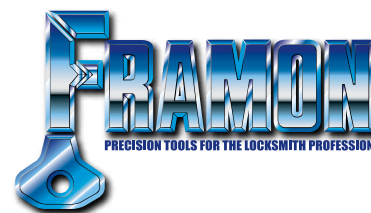

If you need to duplicate detention keys, the JD-12 is for you. The machine is designed exclusively for detention keys such as paracentric & mogul.

Designed on the same principles as other Framon key machines, the JD-12 incorporates cnc-grade linear ball bearings on both the X & Y axis, as well as hardened rods. This gives the machine an extremely smooth motion & allows precise user control. Similar to our Sidewinder high security automotive duplicator, a control lever is mounted on the left side of the machine to control carriage movement.

An interchangeable guide allows the machine to be converted from cutting paracentric-style keys to cutting mogul keys. All cutting wheels for the machine are made of solid carbide. Changing the machine over from paracentric to mogul takes approximately one minute. The JD-12 is preset at the factory to cut paracentric keys; the mogul kit (part number JD-12MK) is available separately.

Like other Framon machines, the JD-12 is covered by our exclusive one year, parts, labor and freight warranty.

JD-12™

Available with 110V AC motor (standard)

220V AC or 12V DC motors (upcharge)

Dimensions: 12" W x 16" D x 10" H

Weight: 35 lbs.



FRAMON MANUFACTURING IS INTRODUCING A NEW FRAME DIMPLING PRODUCT, THE DT-1



The DT-1 tool is designed to aid in metal door frame installation by adding a recess when “field-dimpling” a frame. Examples of use would be installing a new metal frame in an existing masonry or stud opening. The DT-1 is hardened & uses an allen screw & wrench to smoothly add a dimple to the door frame after it has been drilled. Typically, a frame is “punched & dimpled” three to four times on each side of the door frame. The DT-1 makes the job an easy one with a professional looking fit to the fasteners.

The tool is double-sided; after extensive use some wear may be evident in the threads or face of the tool; simply use the opposite side. Two allen screws and a long-arm allen wrench are also included. **Part # DT-1**



T-HANDLE COVER

Framon’s T-Handle cover keeps out dirt, road grime and salt, extending the life of your customers’ lock. Slips over easily and can be moved to the side when locking or unlocking, or simply remove it. Works with most pickup capper T-handles. Sold in packs of 50.

PART # F2MS775

MOTORS

12V DC MOTOR

1/10 hp 42 Frame 1800 RPM 3/8" Shaft DC motor used on all 12V Framon machines. An excellent choice when replacing an older motor on other machines. **PART # F3MT002**



110V AC MOTOR

1/6 hp 48 Frame 1725 RPM 1/2" Shaft AC motor used on newer Sidewinder, TKM-100, and DBM-1 machines with enclosed motor, and newer #2 code machines. **PART# DCMT002**



THESE TOOLS MAKE A HANDY ADDITION TO ANY LOCKSHOP. THEY'VE BEEN TESTED REGULARLY IN OUR OWN LOCKSHOP.

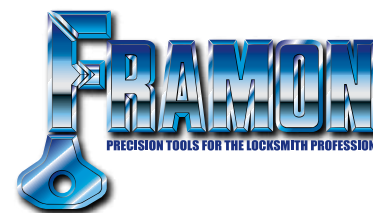

IMPRESSIONING TOOL

Another quality product by Framon Manufacturing Co. that makes key impressioning easier than ever. This tool is self-contained; it needs no wrenches and has no screws to strip out. This tool holds practically any key blank; keys will not rock or slip. The firm hand grip provides complete control when impressioning keys. **PART # IMMS001**



DIAL CALIPERS

6 inch steel dial calipers are easy to read and extremely accurate. Calipers are a must for any serious lockshop whether adjusting a machine or decoding an existing key. Case included. **PART # F2MS451**



DUAL READ DIAL INDICATOR

For locksmiths doing tubular key work, this dial indicator is a must. Use it for decoding keys or checking machine accuracy. Easy to read and simple to use. Graduations in .001" **PART # TKMS451**



QUICK PULL REPLACEMENT BLADES

Framon now offers both Kwikset and Schlage blades for the A1 Quick Pull tool. These replacement blades will fit into the Quick Pull and are steel base material that has been hardened. **Kwikset Replacement Blade PART # QPKW**
Schlage Replacement Blade PART # QPSC



SAFE DEPOSIT KILLER KIT (SDK1)

Framon's new Safe Deposit Killer Kit makes quick & easy work out of drilling S & G and Diebold safe deposit box locks. When traditional methods can't be used due to a plastic or flimsy door the killer kit is your answer. Simply insert the appropriate guide into the keyway and use a hole saw to drill out the face of the plug. Easy entry in minutes. Kit comes with three guides and two-hole saws in an easy to store plastic carrying case. Made in the USA. **PART # SDK1**



TUBULAR LOCK SAW (TLS1)

Framon's TLS1 Tubular Lock Saw allows you to quickly and easily open tubular locks when the key is lost. The TLS1 drills out the bottom pins, giving you the ability to simply insert a blank tubular key and open the lock. The TLS1 fits in any 3/8" or 1/2" drive drill. Call & order yours today! Made in the USA. **PART # TLS1**



MORE GREAT TOOLS FROM FRAMON

BULLSEYE INSTALLATION JIG

Framon is proud to introduce our latest product, the Bullseye Installation Jig. The new installation jig will assist installers with drilling wood or metal doors, both 2-3/8" and 2-3/4" backset. The tool is completely self-contained besides a 3/32" allen wrench to change bore sizes. The tool also features two 1/8" locating holes at 12 & 6 o'clock to locate through bolts on popular lever locks. **PART # BULL**

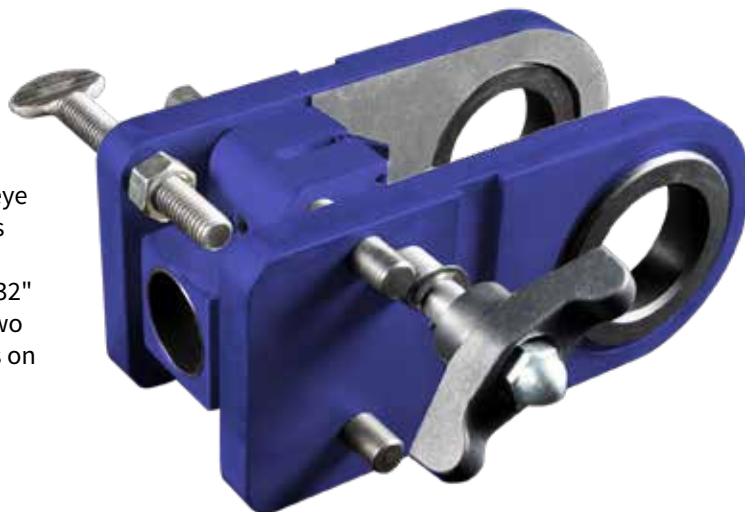

SFIC PINNING / CAPPING BLOCK (CPB1)

Another great tool from Framon Manufacturing for locksmiths who use interchangeable core. The CPB1 comes with a pinning / capping block, ejecting pin and capping tool. Insert the core into the tool and eject the old pins quickly and easily. Flip the block over to load the chambers and cap the core. Made in the USA. **PART # CPB1**



KABA PEAKS PINNING / CAPPING BLOCK (CPB140)

A great tool for locksmiths using Kaba Peaks .140 cylinders. The CPB140 comes with a pinning / capping block, ejecting pin and capping tool. Insert the core into the tool and eject the old pins quickly and easily. Flip the block over to load the chambers and cap the core. Made in the USA. **PART # CPB140**

6 PIN CAPPING TOOL (CBCAP6)

Add the CBCAP6 to your arsenal (works with the CPB140 Tool) and cap an entire Peaks core with one blow of the hammer. Load all your chambers, insert your caps and drive them in place with this handy addition. **PART # CBCAP6**



7 PIN CAPPING TOOL (CBCAP7)

Add the CBCAP7 to your arsenal (works with the CPB1 Tool) and cap an entire core with one blow of the hammer. Load all of your chambers, insert your caps and drive them in place with this handy addition. **PART # CBCAP7**

BLUE DOG KEY COMPANY
YOUR SOURCE FOR THE HARD TO FIND KEYS

Framon purchased the assets of the Blue Dog Key Company in 2016. We have continued to update the line, supplying “hard to find” key blanks to the locksmith industry. BDK only sells to locksmiths, security and select customers in relative industries. We do not sell to the general public. Be sure to register at www.bluedogkeys.com for access to pricing online. Below are some of our top moving key blanks, if they aren’t already on your keyboard they should be!



WE ARE YOUR SOURCE FOR RV KEYS
CHECK OUT THESE RV MASTER CHANGES SETS



TRIMARK RV MASTER KEY SET
 20 Key Set. **PART # BDTMMK**



FIC CHANGE / MASTER KEY SET
 3 Key Set. **PART # BDFICMK**



GLOBAL LINK CHANGE / MASTER KEY SET
 3 Key Set. **PART # BDGLMK**

16-KEY DISPENSER ASSORTMENT

Framon has introduced a 16-key dispenser assortment. Included in the set are keys for Kimberly Clark, Georgia Pacific, Fort Howard, Bobrick, Eagle, SCA/Tork, Baywest, Von Drehle, Merfin, and Bradley. **PART # BDDKS**



WE ARE YOUR SOURCE FOR EQUIPMENT KEYS
CHECK OUT THESE EQUIPMENT KEY SETS

Blue Dog Keys is now offering equipment key sets. These assortments contain 24 of the most popular equipment keys from manufacturers such as John Deere, Komatsu, Kobelco, Hitachi, Cat, Kubota, JLG, Daewoo, Bobcat, JCB, Yanmar and more. The 40-key set adds the next most popular tier.



EQUIPMENT KEY SET

40 Key Set. **PART # BDEKS40**



EQUIPMENT KEY SET

24 Key Set. **PART # BDEKS24**



WWW.BLUEDOGKEYS.COM
sales@bluedogkeys.com

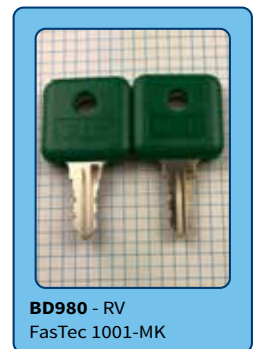
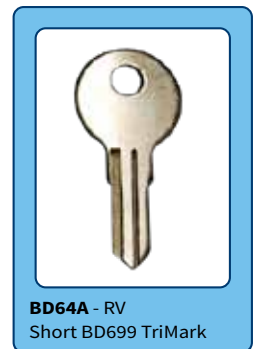
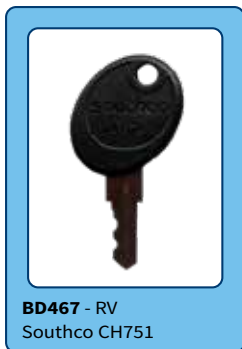

WWW.BLUEDOGKEYS.COM
sales@bluedogkeys.com

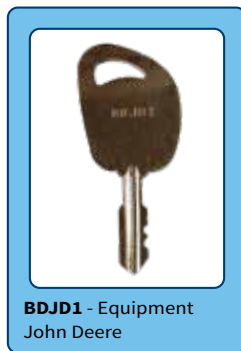
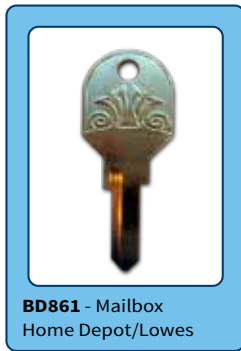
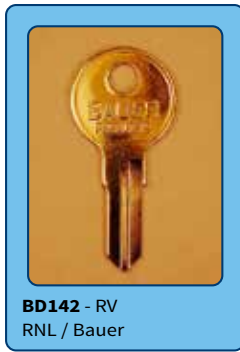



WWW.BLUEDOGKEYS.COM
 sales@bluedogkeys.com

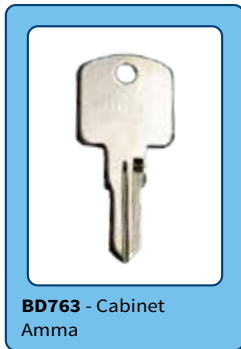
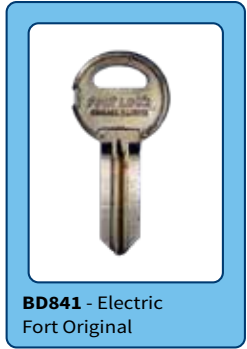

150 KEYS
(5 OF EACH)

Blue Dog Top 30 Assortment!

Get started with Blue Dog Keys with this handy starter pack!

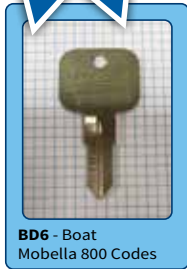

BD6 - Boat
Mobella 800 Codes

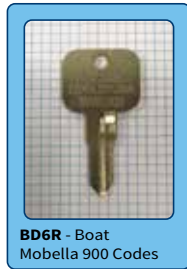

BD6R - Boat
Mobella 900 Codes

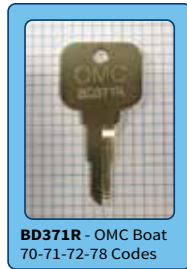

BD371R - OMC Boat
70-71-72-78 Codes

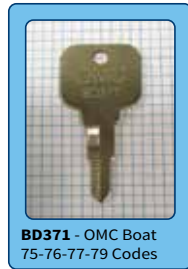

BD371 - OMC Boat
75-76-77-79 Codes

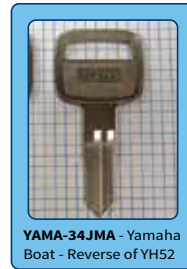

YAMA-34JMA - Yamaha
Boat - Reverse of YH52



BD302 - Dispenser
Precut E114 Code



BD700 - Dispenser
Combination



BD654 - Dispenser
Precut Combination



BD98 - NSR251
Electric Panel Precut

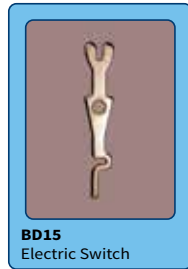

BD15
Electric Switch



BD316
Equipment Precut

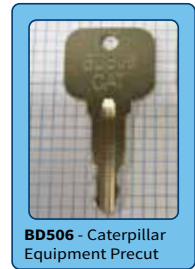

BD506 - Caterpillar
Equipment Precut



BD204 - Generators
Equipment



BD508 - John Deere
Equipment Precut



BD556 - Kubota
Equipment

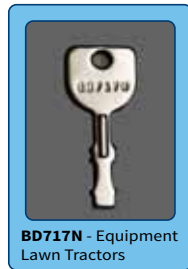

BD171N - Equipment
Lawn Tractors



BD955 - Stack On
Gun Safes

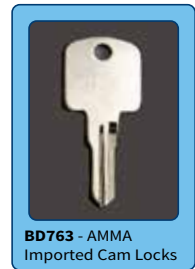

BD763 - AMMA
Imported Cam Locks



BD197A - Armstrong
Imported Cam Locks



BD863 - HD / Lowe's
Mailboxes



BD861 - HD / Lowe's
Mailboxes



BD853 - A-ZUM
Office Furniture

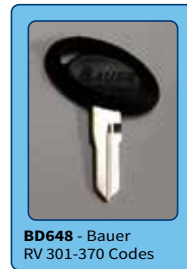

BD648 - Bauer
RV 301-370 Codes

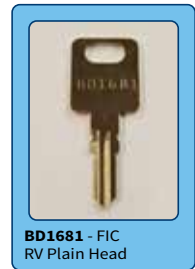

BD1681 - FIC
RV Plain Head



BD984 - Global Link
RV Original



BD467M - SouthCo
RV CH751 Precut



BD61 - Southco RV
E3-5-15 / E3-26-715



BD741M - Southco RV
Precut - R001 Code



BD64 - Trimark
RV - KS720

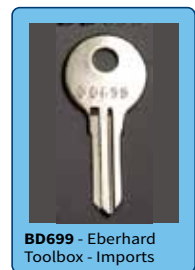

BD699 - Eberhard
Toolbox - Imports

WWW.BLUEDOGKEYS.COM
sales@bluedogkeys.com

ORDER PART #BDT30

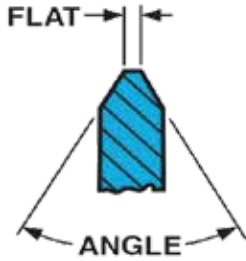

DOUBLE ANGLE MILLING CUTTERS

PART NUMBER	ANGLE	FLAT	OLD PART NUMBER	USED FOR
FC4590T	45°	.090"	-----	Titan Special Cutter
FC7863	78°	.063"	C-10	Sargent Cutter
FC7957	79°	.057"	-----	Kaba Special
FC8445 ^{1,2,3}	84°	.045"	CC-1001	Standard Cutter
FC8615	86°	.015"	CC-001	Medeco Cutter
FC8735	87°	.035"	-----	Foreign Auto Cutter
FC9032	90°	.032"	CC-9032	Assa Cutter
FC9045	90°	.045"	CC-1	Standard Cylinder Cutter
FC9054	90°	.054"	-----	I-Core Cutter / Corbin
FC9063 ²	90°	.063"	-----	Detention Cutter
FC9090	90°	.090"	CC-100B	Kwikset, Weiser, Weslock Cutter
FC10031	100°	.031"	-----	Schlage Cutter
FC10045	100°	.045"	CC-01	Standard Wide Angle Cutter
FC10070	100°	.070"	-----	Detention Wide Angle Cutter

CARBIDE SLOTTER

PART NUMBER	WIDTH	USED FOR
DBC 1035	.035"	Small Letter Box
DBC 1045 ⁴	.045"	Auth, Couch, Eagle, National, Yale
DBC 1055	.055"	Auth, Couch, National, Ilco, Mosler, S & G, Victor
DBC 1066	.066"	Yale, Diebold, HHM, S & G, Security, York
DBC 1085S	.085"	Southern Steel A1
DBC 1088	.088"	Ilco, LeFebure, Mosler, Security
DBC 1103 ²	.103"	Prison Locks - Southern Steel

HIGH SPEED STEEL SLOTTER

PART NUMBER	WIDTH	USED FOR
FFS 1020	.020"	Filler Slotter
FFS 1030	.030"	Cabinet & Mailboxes
1FFS 1045	.045"	Auth, Couch, Eagle, National
FFS 1055	.055"	S & G, Victor, Florence
FFS 1066	.066"	HHM, S & G, Yale, York, Diebold
FFS 1088	.088"	LeFebure, Mosler

AUTOMOTIVE CUTTERS FOR DC-300 / FRA-2001

PART NUMBER	WIDTH	USED FOR
DC9040	90°/.040"	Standard DC-300 Cutting Wheel
DC9040ALC	90°/.040"	Coated DC-300 Cutting Wheel
DC9040C	90°/.040"	Carbide DC-300 Cutting Wheel

ALL CUTTERS

.375 I.D. - 2.375 O.D. + .0005 TOLERANCE

1. Denotes cutter supplied with #2 Code Machine
2. Denotes cutter supplied with #2J Code Machine
3. Denotes cutter supplied with #1 Code Machine
4. Denotes cutter supplied with DBM-1 Machine

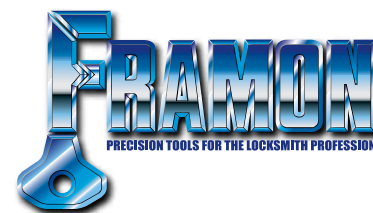
**FRAMON #1, #2 CODE MACHINES**

Drive Belt	F2MS601
Key Stop.....	F2MS551
Standard Vise	F2SH060
Depth Plate (.100, .150 markings)	F2MS102
Depth Plate Pointer.....	F2MS104
Spacing Block Indicator.....	F2MS105
Compression Spring (vise springs, sold in packs of five)	F2MS001-PK5
Spacing Clip.....	F2MS552

EXPRESS

Cutter	LK84STiALN
Drive Belt	JDMS601

TKM-100

Drive Belt	GHMS601
Older TKM-100 (models with wood base).....	TKMS601
Cutter	TCA1001
Collet.....	TKSH017

DBM-1

Wire Brush	DCMS252
Nylon Brush	DCMS251
Drive Belt	GHMS601

SIDEWINDER / SIDEWINDER 2

Drive Belt	F2MS601
Hand Held Tip Stop	GESH029
Standard Vise Set	GHSH0601

MD-1

Cutter	FC078P
Drive Belt	JDMS601

WE OFFER A VARIETY OF RESOURCES TO OUR CURRENT & POTENTIAL CUSTOMERS!

LEARN MORE ABOUT FRAMON

First, visit the Framon website at www.framon.com for product information, key machine manuals, and other relevant information.

If you are considering a Framon key machine, visit our YouTube page at www.youtube.com/user/FramonManufacturing. Videos of all of our products are available here including setup and adjustments for many of our machines.

Join our Facebook page by searching for “Framon Manufacturing” or just go to www.facebook.com/FramonMFG. New product announcements and updates are announced using our Facebook page.

For software tech support, we regularly use “TeamViewer” which is a remote login program. Using TeamViewer our customer service person can connect to your computer (as long as an internet connection is present) and quickly diagnose or fix the problem. For quickest results, install TeamViewer prior to calling us by clicking the “TeamViewer” link at the top of our home page.

As always, call us at **989-354-5623** for assistance, tech support or product questions. We are available from 8:00 AM to 4:30 PM Eastern Time, Monday through Friday.

Join our email list to get regular product updates and new information weekly. Just send your email address to sales@framon.com to sign up!



Framon Manufacturing Company
1201 West Chisholm Street
Alpena, Michigan 49707

www.framon.com